

Surface Mount Multilayer Varistor

SC0805ML - SC2220ML Series

Description

The SC Series is based on Multilayer fabrication technology. These components are designed to suppress a variety of transient events, including those specified in IEC 61000-4-2 or other standards used for Electromagnetic Compliance (EMC). The SC Series is typically applied to protect integrated circuits and other components at the circuit board level. It can operate over a wider temperature range than zener diodes.



Features

- u Rectangle, sizes serialization for hybrid integrated circuit or printed circuit surface mount components
- u There are many side electrode lead-out material, particularly suitable for surface mount technology for solderability and resistance to soldering heat of the stringent requirements
- u Fast response (<1ns)
- u Low leakage current, low clamping voltage
- u Suitable for reflow, wave soldering and hot air hand soldering

Equivalent Circuits

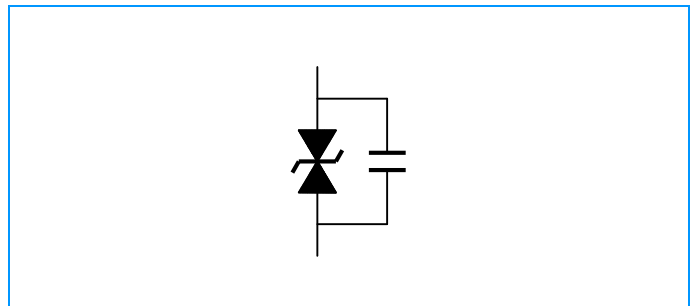

Applicable

- u Application for Mother Board, Notebook, Cellular Phone, PDA, handheld device, DSC, DV, Scanner, and Set- Top Box...etc.
- u Suitable for Push-Button, Power Line and Low Frequency single line over-voltage protect.

Explanation of Part Number

SC	0805	ML	080	M
(1)	(2)	(3)	(4)	(5)

- (1) Socay Logo
- (2) Chip Size (EIA): 0402 / 0603
- (3) Series Type: ML- Multilayer Varistor
- (4) Varistor Voltage: Value - 080= 08X10⁰=8V, 120=12X10⁰=12V
- (5) Varistor Voltage Tolerance: N - ±30%, M - ±20%, L - ±15%, K - ±10%

Surface Mount Multilayer Varistor

SC0805ML - SC2220ML Series

Electrical Characteristics (25±5° C)

SC0805ML Series

Test Condition	Working Voltage		Varistor Voltage	Clamping Voltage	Peak Current	Transient Energy	Capacitance
	<20μA		@1mA DC	8/20μs	8/20μs	10/1000μs	1KHz
	DC	AC RMS					
Symbol	V _{DC}	V _{RMS}	V _B	V _C	I _P	E _T	C _P
Units	Volts (Max.)	Volts (Max.)	Volts	Volts (Max.)	Amps (Max.)	Joules (Max.)	pF
SC0805ML050M	3.3	2.0	4.0~6.0	10.0	40	0.1	1190~2210
SC0805ML080M	5.6	4.0	6.4~10.1	15.5	40	0.1	770~1430
SC0805ML120M	9.0	6.0	10.8~16.2	25.0	40	0.1	560~1040
SC0805ML150M	11.0	8.0	13.2~19.8	30.0	40	0.1	525~975
SC0805ML180K	14.0	11.0	16.8~25.2	40.0	40	0.1	434~806
SC0805ML240K	18.0	14.0	21.6~32.4	54.0	40	0.1	385~715
SC0805ML270K	22.0	17.0	26.4~39.6	65.0	40	0.1	336~624
SC0805ML330K	26.0	20.0	31.2~46.8	75.0	40	0.1	280~520
SC0805ML390K	30.0	25.0	36.0~54.0	85.0	40	0.1	210~390

SC1206ML Series

Test Condition	Working Voltage		Varistor Voltage	Clamping Voltage	Peak Current	Transient Energy	Capacitance
	<20μA		@1mA DC	8/20μs	8/20μs	10/1000μs	1KHz
	DC	AC RMS					
Symbol	V _{DC}	V _{RMS}	V _B	V _C	I _P	E _T	C _P
Units	Volts (Max.)	Volts (Max.)	Volts	Volts (Max.)	Amps (Max.)	Joules (Max.)	pF
SC1206ML050M	3.3	2.0	4.0~6.0	10.0	100	1.0	3010~5590
SC1206ML080M	5.6	4.0	6.4~10.1	15.5	100	1.0	2170~4030
SC1206ML120M	9.0	6.0	10.8~16.2	25.0	100	1.0	1400~2600
SC1206ML180K	14.0	11.0	16.8~25.2	40.0	100	1.0	1120~2080
SC1206ML240K	18.0	14.0	21.6~32.4	54.0	100	1.0	980~1820
SC1206ML270K	22.0	17.0	26.4~39.6	62.0	100	1.0	910~1690
SC1206ML330K	26.0	20.0	31.2~46.8	73.0	100	1.0	770~1430
SC1206ML390K	30.0	25.0	36.0~54.0	85.0	100	1.0	700~1300
SC1206ML470K	39.0	30.0	46.8~70.2	105.0	100	1.0	560~1040
SC1206ML680K	56.0	40.0	67.2~100.8	150.0	100	1.0	300~500
SC1206ML101K	75.0	50.0	90.0~135.0	200.0	100	1.0	180~380

Surface Mount Multilayer Varistor

SC0805ML - SC2220ML Series

Electrical Characteristics (25±5° C) (Continue)

SC1210ML Series

Test Condition	Working Voltage		Varistor Voltage @1mA DC	Clamping Voltage 8/20µs	Peak Current 8/20µs	Transient Energy 10/1000µs	Capacitance 1KHz
	DC	AC RMS					
Symbol	V _{DC}	V _{RMS}	V _B	V _C	I _P	E _T	C _P
Units	Volts (Max.)	Volts (Max.)	Volts	Volts (Max.)	Amps (Max.)	Joules (Max.)	pF
SC1210ML180K	14.0	11.0	16.8~25.2	40	250	1.5	1190~2210
SC1210ML240K	18.0	14.0	21.5~32.4	51	250	1.5	532~988
SC1210ML270K	22.0	17.0	26.4~39.6	62.0	250	1.5	490~910
SC1210ML330K	27.0	20.0	32.4~46.8	75.0	250	1.5	476~884
SC1210ML390K	30.0	25.0	36.0~54.0	85.0	250	1.5	378~702
SC1210ML470K	40.0	30.0	48.0~86.4	105.0	250	1.5	336~624
SC1210ML560K	45.0	35.0	54.0~81.0	125.0	250	1.5	413~767
SC1210ML680K	56.0	40.0	67.2~100.8	150.0	250	1.5	280~520
SC1210ML101K	75.0	50.0	90.0~135.0	200.0	250	1.5	203~377

SC1812ML Series

Test Condition	Working Voltage		Varistor Voltage @1mA DC	Clamping Voltage 8/20µs	Peak Current 8/20µs	Transient Energy 10/1000µs	Capacitance 1KHz
	DC	AC RMS					
Symbol	V _{DC}	V _{RMS}	V _B	V _C	I _P	E _T	C _P
Units	Volts (Max.)	Volts (Max.)	Volts	Volts (Max.)	Amps (Max.)	Joules (Max.)	pF
SC1812ML240K	18.0	14.0	21.6~32.4	51.0	800	2.3	3080~5720
SC1812ML270K	24.0	18.0	28.8~43.2	67.0	800	2.7	2100~3900
SC1812ML330K	28.0	21.0	33.6~50.4	78.0	800	2.9	1820~3380
SC1812ML390K	30.0	22.0	36.0~54.0	83.0	800	2.9	1610~2290
SC1812ML560K	45.0	33.0	54.0~81.0	124.0	800	3.1	1260~2340
SC1812ML620K	48.0	35.0	57.6~86.4	132.0	800	3.2	910~1690

Surface Mount Multilayer Varistor

SC0805ML - SC2220ML Series

Electrical Characteristics (25±5° C) (Continue)

SC2220ML Series

Test Condition	Working Voltage		Varistor Voltage	Clamping Voltage	Peak Current	Transient Energy	Capacitance
	<20μA		@1mA DC	8/20μs	8/20μs	10/1000μs	1KHz 1Vrms
	DC	AC RMS					
Symbol	V _{DC}	V _{RMS}	V _B	V _C	I _P	E _T	C _P
Units	Volts (Max.)	Volts (Max.)	Volts	Volts (Max.)	Amps (Max.)	Joules (Max.)	pF
SC2220ML240K	18.0	14.0	21.6~27.0	51.0	1200	5.8	9800~18200
SC2220ML270K	22.0	17.0	26.4~39.6	62.0	1200	7.2	7700~14300
SC2220ML330K	27.0	20.0	32.4~46.8	75.0	1200	7.8	7000~13000
SC2220ML390K	30.0	25.0	36.0~54.0	85.0	1200	7.8	6300~11700

Surface Mount Multilayer Varistor

SC0805ML - SC2220ML Series

Dimensions

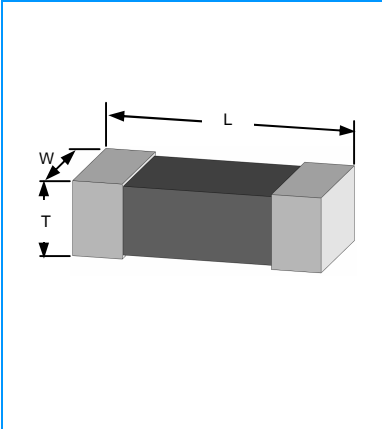

Size EIA (EIAJ)	Length (L)		Width (W)		Thickness (T)	
	Inches	Millimeters	Inches	Millimeters	Inches	Millimeters
0805 (2012)	0.079±0.008	2.00±0.20	0.049±0.006	1.25±0.15	0.047 Max	1.20 Max
1206 (3216)	0.126±0.008	3.20±0.20	0.063±0.006	1.60±0.15	0.059 Max	1.50 Max
1210 (3225)	0.126±0.008	3.20±0.20	0.098±0.008	2.50±0.20	0.059 Max	1.50 Max
1812 (4532)	0.177±0.008	4.50±0.20	0.126±0.008	3.20±0.20	0.079 Max	2.00 Max
2220 (5750)	0.224±0.008	5.70±0.20	0.197±0.008	5.00±0.20	0.098 Max	2.50 Max

Soldering Recommendations

I Recommended solder Pad Layout

Size EIA (EIAJ)	A		B		C		D	
	Inches	Millimeters	Inches	Millimeters	Inches	Millimeters	Inches	Millimeters
0805 (2012)	0.039~0.059	1.0~1.5	0.126~0.150	3.2~3.8	0.047~0.055	1.2~1.4	0.012~0.024	0.3~0.6
1206 (3216)	0.071~0.098	1.8~2.5	0.165~0.228	4.2~5.8	0.047~0.063	1.2~1.6	0.016~0.032	0.4~0.8
1210 (3225)	0.071~0.098	1.8~2.5	0.165~0.228	4.2~5.8	0.071~0.098	1.8~2.5	0.020~0.040	0.5~1.0
1812 (4532)	0.098~0.138	2.5~3.5	0.217~0.240	5.5~6.1	0.091~0.126	2.3~3.2	0.024~0.043	0.6~1.1
2220 (5750)	0.138~0.181	3.5~4.6	0.236~0.283	6.0~7.2	0.189~0.217	4.8~5.5	0.047~0.090	1.2~2.3

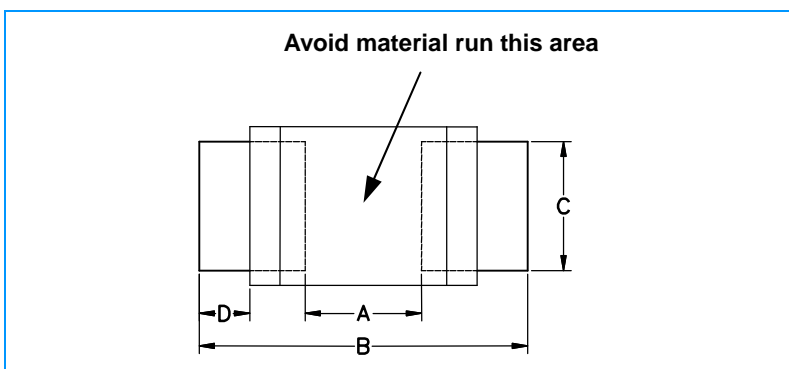

- I The solder paste shall be printed in a thickness of 150 to 200µm.
- I The SIR test of the solder paste shall be done (Base on JIS-Z-3284)

I IR Soldering

Rapid heating, partial heating or rapid cooling will easily cause defect of the component. So preheating and gradual cooling process is suggested. IR soldering has the highest yields due to controlled heating rates and solder liquidus times. Make sure that the element is not subjected to a thermal gradient steeper than 4 degrees per second. 2 degrees per second is the ideal gradient. During the soldering process, pre-heating to within 100 degrees of the solder peak temperature is essential to minimize thermal shock.

Surface Mount Multilayer Varistor

SC0805ML - SC2220ML Series

Soldering Recommendations (Continue)

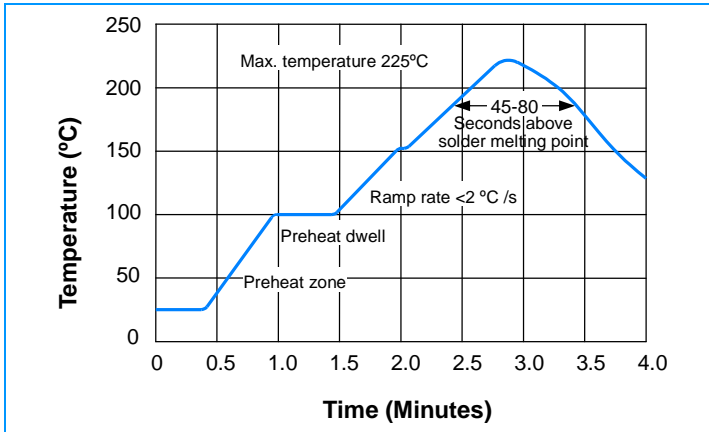

(a) Preheat

1. The temperature rising speed is suggested to be 2~4 °C /s
2. Appropriate preheat time will be from 60 to 120 seconds.

(b) Heating

1. Careful about sudden rise in temperature as it may worsen the solder ability.
2. Set the peak temperature in the range from 215 °C to 225 °C.

(c) Cooling

1. Careful about slow cooling as it may cause the position shift of component.

I Hand Soldering

In hand soldering of the varistors. Large temperature gradient between preheated the varistors and the tip of soldering iron may cause electrical failures and mechanical damages such as cracking or breakings of the devices. The soldering shall be carefully controlled and carried out so that the temperature gradient is kept minimum with following recommended conditions for hand soldering.

(a) Recommended Soldering Condition 1

1. Solder:
 - 1mm Thread solder (sn63:pb37) with soldering flux in the core.
 - Rosin-based and non-activated flux is recommended.
2. Preheating
 - The varistors shall be preheated so that Temperature Gradient between the devices and the tip of soldering iron is 150 °C or below.
3. Soldering Iron
 - Rated Power of 20w max with 3mm soldering tip in diameter.
 - Temperature of soldering iron tip 300C max (The required amount of solder shall be melted in advance on the soldering tip.)
4. Cooling
 - After soldering. The varistors shall be cooled gradually at room ambient temperature.

(b) Recommended Soldering Condition 2 (Without preheating)

1. Solder iron tip shall not directly touch to ceramic dielectrics.
2. Solder iron tip shall be fully preheated before soldering while soldering iron tip to the external electrode of varistors.

I Post Soldering Cleaning

- (a) Residues of corrosive soldering fluxes on the PC board after cleaning may greatly have influences on the electrical characteristic and the reliability (such as humidity resistance) of the varistors which have been mounted on the board. It shall be confirmed that the characteristic and the reliability of the devices are not affected by the applied cleaning conditions.
- (b) When an ultrasonic cleaning is applied to the mounted varistors on PC Boards. Following conditions are recommended for preventing failures or damages of the devices due to the large vibration energy and the resonance caused by the ultrasonic waves.
 1. Frequency 29MHz max
 2. Radiated Power 20w/lithr max
 3. Period 5minuets max

Surface Mount Multilayer Varistor

SC0805ML - SC2220ML Series

Surge Waveform

Wave shape "Short Circuit" (Current I_{sc})

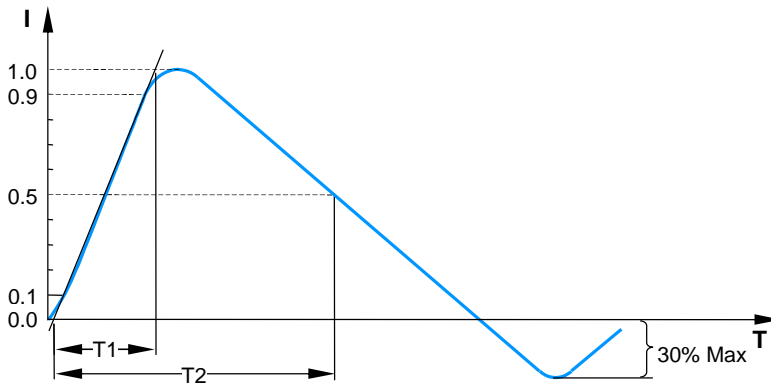

IEC 61000-4-2 Compliant ESD Current Pulse Waveform

IEC61000-4-5 Standards

SEVERITY LEVEL	T1	T2
1	8 μ s	20 μ s
2	10 μ s	1000 μ s

Environmental & Reliability Testing

Characteristic	Test method and description			
High Temperature Storage	The specimen shall be subjected to $125\pm 2^\circ\text{C}$ for 1000 ± 2 hours in a thermostatic bath without load and then stored at room temperature and humidity for 1 to 2 hours. The change of varistor voltage shall be within 10%.			
Temperature Cycle	The temperature cycle of specified temperature shall be repeated five times and then stored at room temperature and humidity for one two hours. The change of varistor voltage shall be within 10% and mechanical damage shall be examined.	Step	Temperature	Period
		1	$-40\pm 3^\circ\text{C}$	30min ± 3
		2	Room Temperature	1~2hours
		3	$125\pm 2^\circ\text{C}$	30min ± 3
		4	Room Temperature	1~2hours
High Temperature Load	After being continuously applied the maximum allowable voltage at 85°C for 1000hours, the specimen shall be stored at room temperature and humidity for one or hours, the change of varistor voltage shall be within 10%.			
Damp Heat Load/ Humidity Load	The specimen should be subjected to 40°C , 90 to 95%RH environment, and the maximum allowable voltage applied for 1000 hours, then stored at room temperature and humidity for one or two hours. The change of varistor voltage shall be within 10%.			
Low Temperature Storage	The specimen should be subjected to -40°C , without load for 1000 hours and then stored at room temperature for one two hours. The change of varistor voltage shall be within 10%.			

General Technical Data

Operating Temperature	-55~85 $^\circ\text{C}$
Storage Temperature	-55~150 $^\circ\text{C}$
Response Time	<1 ns
Solderability	245 $\pm 5^\circ\text{C}$, 3 ± 1 sec
Solder Leach Resistance	260 $\pm 5^\circ\text{C}$, 10 ± 1 sec

Surface Mount Multilayer Varistor

SC0805ML - SC2220ML Series

Packaging Information

Carrier Tape Dimensions

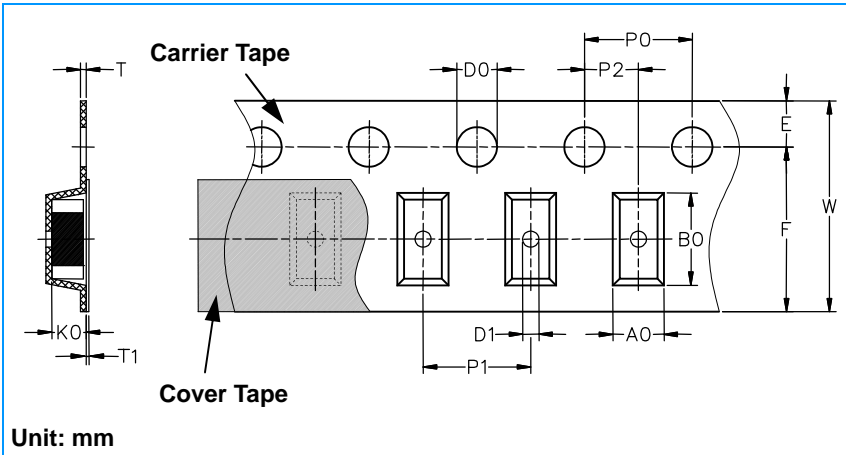

Carrier tape transparent cover tape should be heat-sealed to carry the products, and the reel should be used to reel the carrier tape.

The adhesion of the heat-sealed cover tape shall be 40+20/-15 grams.

Both the head and the end portion of taping shall be empty for reel package and SMT auto-pickup machine. And a normal paper tape shall be connected in the head of taping for the operator handle.

Unit: mm

Symbol	A0 ±0.10	B0 ±0.10	K0 ±0.10	T ±0.05	T1 ±0.05	D0 +0.10 -0.00	D1 ±0.05	P1 ±0.10	P2 ±0.05	P0 ±0.050	W ±0.20	E ±0.10	F ±0.05
0805	1.42	2.30	1.04	0.22	0.10	1.50	1.00	4.00	2.00	4.00	8.00	1.75	3.50
1206	1.88	3.50	1.27	0.20	0.10	1.50	1.00	4.00	2.00	4.00	8.00	1.75	3.50
1210	2.18	3.46	1.45	0.22	0.10	1.50	1.00	4.00	2.00	4.00	8.00	1.75	3.50
1812	3.66	4.95	1.74	0.25	0.10	1.50	1.50	8.00	2.00	4.00	12.00	1.75	5.50
2220	5.10	5.97	2.80	0.25	0.10	1.50	1.50	8.00	2.00	4.00	12.00	1.75	5.50

Taping Reel Dimensions

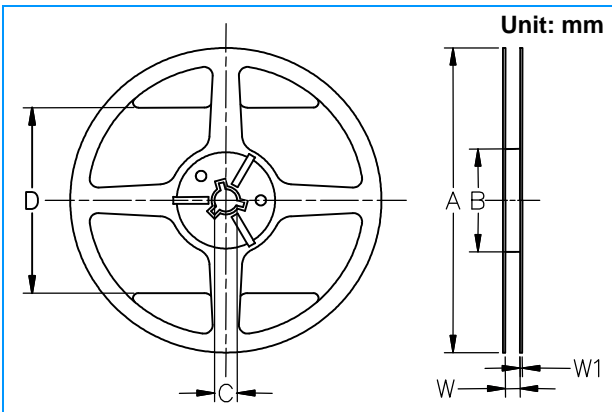

Symbol	A	B	C	D	W	W1
0805	178.0±1.0	60.0±0.5	13.0±0.2	110.0±0.5	9.0±0.5	1.5±0.15
1206	178.0±1.0	60.0±0.5	13.0±0.2	110.0±0.5	9.0±0.5	1.5±0.15
1210	178.0±1.0	60.0±0.5	13.0±0.2	110.0±0.5	9.0±0.5	1.5±0.15
1812	178.0±1.0	60.0±0.5	13.0±0.2	110.0±0.5	13.6±0.5	1.5±0.15
2220	178.0±1.0	60.0±0.5	13.0±0.2	110.0±0.5	13.6±0.5	1.5±0.15

Taping Specifications

There shall be the portion having no product in both the head and the end of taping, and there shall be the cover tape in the heat of taping.

Quantity of products in the taping package

SIZE EIA (EIAJ)	0805 (2012)	1206 (3216)	1210 (3225)	1812 (4532)	2220 (5750)
Standard Packing Quantity (PCS / reel)	3,000	3,000	2,000	1,000	1,000

The contents of a box :

- 0805 Series: 6 reels / inner box
- 1206 Series: 6 reels / inner box
- 1210 Series: 6 reels / inner box
- 1812 Series: 6 reels / inner box
- 2220 Series: 6 reels / inner box

Label and Marking:

The paper label shall be plastered on the obvious side of the reel, and the information show as right side